

Chairman's Message



And it's May! Where has this year gone? I hope, if you were able to, that you managed to enjoy a drink/meal outdoors.....I certainly did (quite a few times) and it felt wonderful. Looking forward to 17 May, with a few more restrictions lifted.

At our April monthly Zoom meeting, we enjoyed a performance by Fool's Gold Acoustic. Very entertaining afternoon on a cold, wet and windy afternoon! This month's meeting will be the last (for the time being on Zoom) and we welcome David Gane back on Monday 17 May at 2 p.m. answer such scientific questions as 'how do we know the sun will rise tomorrow'? Interesting stuff.

Later in the bulletin is an article about Membership Renewals, hope that you find that helpful.

We are in the process of inducting/handing over to Chris and Nigel (joint Membership Secretaries) and Hilary (Speakers Secretary). This is proving a little more challenging via Zoom than face to face, but we're getting there. The newly formed Wellbeing Group is working on its role, and we'll send out more information over the next few weeks. The aim of the group is to support members to re-engage with Waterlooville u3a following the long period of not meeting in person.

We are still seeking an Assistant Treasurer and a Vice-Chair. These are both interesting roles, so if you are remotely interested in finding out a little more, please do get in touch with me

chairman@waterloovilleu3a.org.uk with absolutely no obligation!! I would love to hear from you.

There are a few events planned in the next couple of months (more details will be emailed out, on the website and FaceBook 'events and activities' page [Waterlooville u3a | Facebook](#) as well as in the bulletin)

Wednesday 02 June – u3a Day (in line with National event). We will be at the Bandstand in Waterlooville 10am–4pm.

Wednesday 30 June – Welcome Back.....opportunity to meet your committee, members of the wellbeing team, enjoy afternoon tea and scones along with last opportunity to renew your membership in person. Venue to be confirmed

Friday 06 August – Open Day and 15 Year Anniversary celebrations. Waterlooville Community Centre

Wednesday 08 September – Cheese and Wine, AGM followed by a Quiz. Venue to be confirmed.

Wednesday 22 September – Monthly meeting. Venue and speaker to be confirmed.

Thank you so much to the current Events Team and the new Communications Team volunteers for their help in co-ordinating this programme. I am really looking forward to meeting you in person as I hope you can attend at least some of these events. With my very best wishes, Jo

New Members

A warm welcome to the following new members who joined in the last month or so:

Mark Lee, Maureen Mulcahy, Elaine Jarvis, Sue Wynne, Sandy Blakeborough, Ruth Walker, Beverley Smith, David Price (rejoined)

Waterlooville u3a Membership Renewal

Meet the New Membership Team

We are delighted to have new joint Membership Secretaries, Chris and Nigel Barrell. Sue B and Alison E are joining the team as Membership Co-ordinators, with a few more volunteer members on hand to assist with membership as and when necessary. Welcome to all, and I know you'll be an asset to Waterlooville u3a.

New Membership Year

As previously advised, the membership year will run from **01 July 2021**.

Membership Fees

These remain unchanged – £20 joint members; £11 individual members and £7.50 associate members.

Membership Cards

These will no longer be issued, as they are neither cost effective, nor time efficient. If you currently have a membership card, please keep hold of it as it will now last indefinitely.

Invitation to Renew your Membership

This will be sent out via email (or posted if you do not have an email address) by the new Membership Secretaries in the next two to three weeks, and will include:

How to make payment

New bank account details

Reminder to let us know of any changes e.g. contact details and gift aid eligibility

The bank account has been changed, so until you receive the invitation, please do not make payment to the previous bank account, thank you.

I think that is all for now. Please do look out for the renewal invitation, and if you have any queries in the meantime feel free to drop me an email.

Many thanks, Jo

Jo Derham

Temporary Membership Secretary

Group Liaison Corner



GROUPS RESTARTING

In addition to the dozen or so groups that restarted last month, the following have or intend to start this month:

- Current Affairs 1
- Current Affairs 2
- German (Advanced)
- Jazz & Blues Appreciation
- Local History 4
- Music Appreciation
- Needle Craft
- Outings 1
- Photography 3
- Photography 4
- Pilates 1
- Pilates 2
- Spanish Conversation 2
- Walking 2 - Striders

WAITING LISTS Would you like to check that you are on a waiting list? Just ask me and I'll tell you if you are. Waiting lists are for groups that are full, but if a list gets big enough, we may start a new group!

To contact Group Liaison, email Kevin Stock at groups@waterloovilleu3a.org.uk
Tel: 023 9217 9298

* NEW GROUP *

Members On Their Own

Group Coordinator: David Turland.

The aim of the group would be to provide companionship for Members who are on their own and would like to take part in a variety of activities, but would rather not do so alone. It could be day or half-day. Members could take turns to suggest an outing - perhaps visit a garden, a place of interest, have a lunch, visit the theatre or go to a concert. Or meet at a garden centre for coffee and cake...

It should be fun!

We have a Group Coordinator already.

Now we need some members...

If you are on your own and think this is a good idea, write to Kevin and he will add you to the list of interested people.

Article submitted by David Turland, u3a Member

Stay Local

We are in this months edition of the Stay Local magazine on page 19.

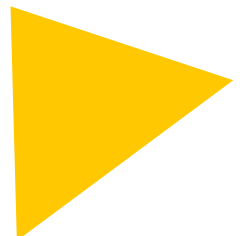

Dates for your Diary

Monday 17th May 2pm – Monthly Meeting on Zoom. Anyone can do it – A beginner's guide to Science. Speaker: David Gane

Wednesday 2nd June 10am – 4pm National u3a day – The Bandstand, Waterlooille

Monday 14th June 10am – Coffee Morning on Zoom

Wednesday 30th June 2pm – Welcome Back! Drop in between 2pm and 4pm for tea & a chat. Venue to be confirmed.

Friday 6th Aug 2pm Open Day & 15th Anniversary at Waterlooille Community Centre

Wednesday 8th Sept 2pm – Cheese & wine, AGM, and a Quiz! Venue to be confirmed.

u3a Facebook Group

We have a Facebook Group for Waterlooille u3a that any member can join. It's a way for you to post items that you think will be of interest to other members. and for us to remind you of u3a events coming up. Just search for 'Waterlooville u3a Members Group' from Facebook and request to join!

u3a Facebook Page

We also have a Facebook Page called 'Waterlooville u3a' A page is like an advert for us – anyone can see it. You don't join a Page, instead you click 'like' and you will see any post we make. Ask your friends and family to 'like' it too!

The Great British Sewing Bee

We have received the following...

I am writing to let you know that we are now looking for the next collection of amateur sewers to take part in Series 8 of The Great British Sewing Bee!

We are keen to hear from sewers of all ages, so if you or someone you know is a talented amateur sewer then please do encourage them to apply at www.applyforsewingbee.co.uk

Applications Close: 11.59am on Monday 24th May 2021

It would be very much appreciated if you would help us spread the word to anyone who may be interested. We would be more than happy to answer any questions at : applyforsewingbee@loveproductions.co.uk

With very best wishes

The Great British Sewing Bee team

MEMBER LEAD ARTICLES

We hope to start a regular member lead article each month, so please submit something for the next edition! The first one is from our Birdwatching group.

u3a Birdwatching Group 2

Saturday 10th April 2021

On a cold and cloudy Sat morning our group of Birdwatchers met at Farlington Marshes Nature Reserve Main Car Park. There were nine of us and split loosely in to two groups to adhere to socially distancing rules.

The group consisted of Lin and Mike, Margaret and David, Jo , Richard, John and Monica and Terry.

We started the walk at 10 am and enjoyed a 3 hour walk with frequent stops for Birding. It turned into a very rewarding walk both for birds and socialising (much needed after Lock-down). The following list is of the birds we managed to see and hear

1. Little Egrets – Now breed in Britain
2. Herring Gulls
3. Black Headed Gull
4. Mediterranean Gulls
5. Large group of Black Tailed Godwits on the lake and later a single in summer plumage
6. Avocets
7. Redshanks
8. Starlings
9. Meadow Pipit singing
10. Cormorant
11. Mallard Ducks – male and females
12. Gadwall Ducks – 1 pair
13. Canada Geese
14. Shelduck – many
15. Lapwing (Peewit)
16. Moorhens
16. Coot
17. Kestrel hovering near the Group.
18. Starlings.
19. Blackbirds
20. Skylarks.
21. Cetti's Warbler
22. Pheasants – male and female
23. Swallows – just arrived from Africa
24. Curlews
25. Brent Geese – last stragglers before migration to the Russian Tundra
26. Widgeon
27. Teal
- 28 Robin
29. Chiff Chaff – first Warbler arrivals
30. Great Tit
31. Oystercatcher
32. Carrion Crow
33. Woodpigeon

And finally, as we completed the walk, John Phillips offered each of us a piece of specially homemade Fruit Cake. Many thanks John and to everybody for such a lovely morning.

Mike

Answers to the April Puzzle Pages

Easter

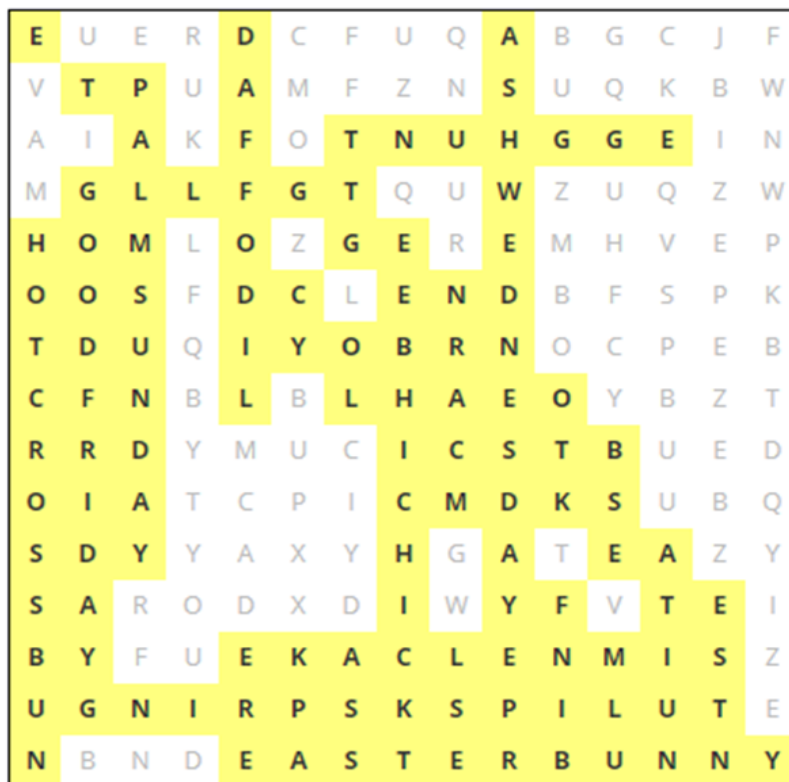

ASH WEDNESDAY	GOOD FRIDAY
BASKET	HOT CROSS BUN
BONNET	PALM SUNDAY
CHICK	SIMNEL CAKE
CHOCOLATE	SPRING
DAFFODIL	TULIPS
EASTER BUNNY	
EASTER EGG	
EGG HUNT	
FAMILY	

Avgolemono – a Greek egg-lemon soup.

Colomba Pasquale – an Italian Easter bread with candied peel and almonds.

Cozonac – a Bulgarian Easter bread rich in eggs, milk, and butter.

Deville Eggs – eggs stuffed with their yolk mixed with other ingredients like mayonnaise and mustard. Popular in the Southern United States.

Flaounes – a Greek-Cypriot Easter cheese bread.

Galaktoboureko – a Greek dessert of semolina custard baked in filo pastry.

Hot Cross Buns – a spiced sweet dried fruit bun marked with a cross on top, traditionally eaten on Good Friday in the countries including the UK, Ireland, Australia, and New Zealand.

Koulourakia – a Greek butter-based pastry with a slight vanilla flavor.

Mazurek – a very sweet flat cake baked in Poland for Easter.

Peeps – colourful marshmallows sold in the USA and Canada that are shaped like chicks, bunnies, and other animals for various holidays including Easter.

Simnel Cake – an English fruit cake with a layer of marzipan, and 11 balls of marzipan sitting around the top of the cake to symbolize the apostles – less than 12 because of the missing Judas.

Tsoureki – a sweet bread made seasoned with orange zest and mastic resin. From Greece, Turkey, and the Balkans region.



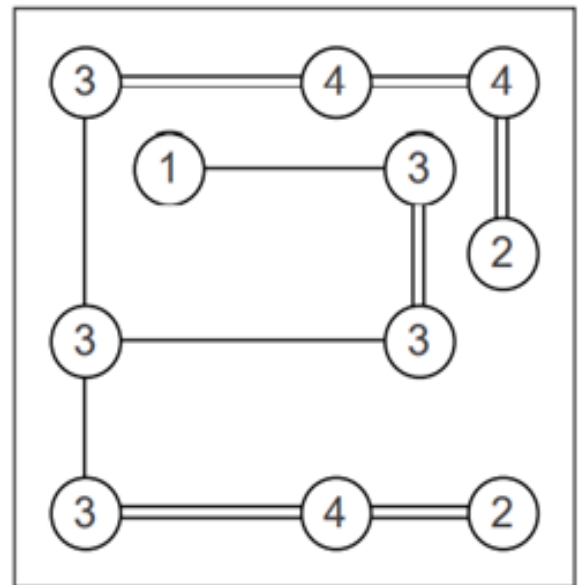
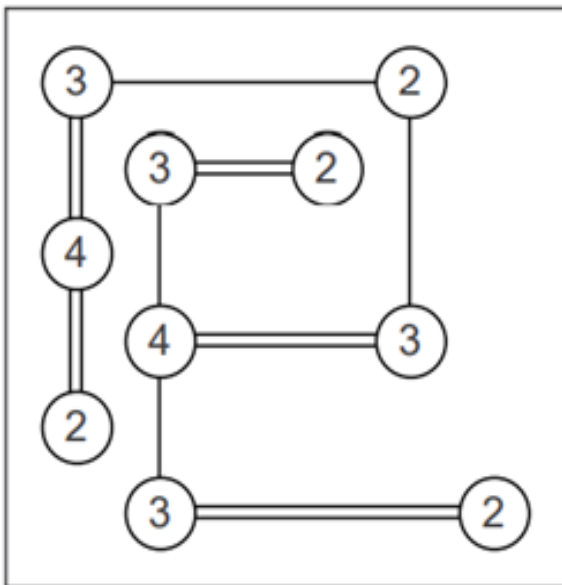
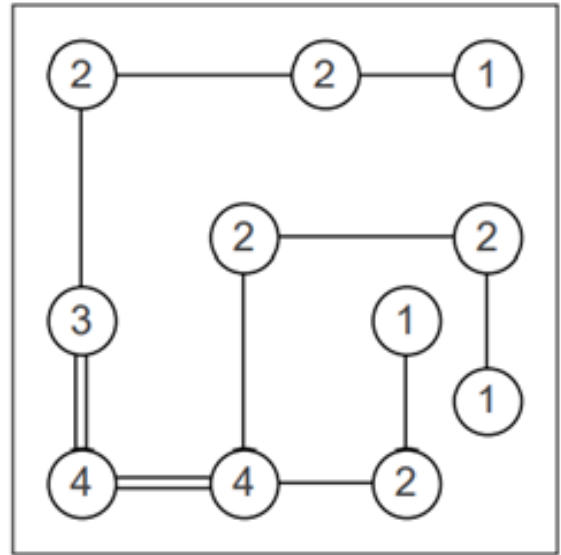
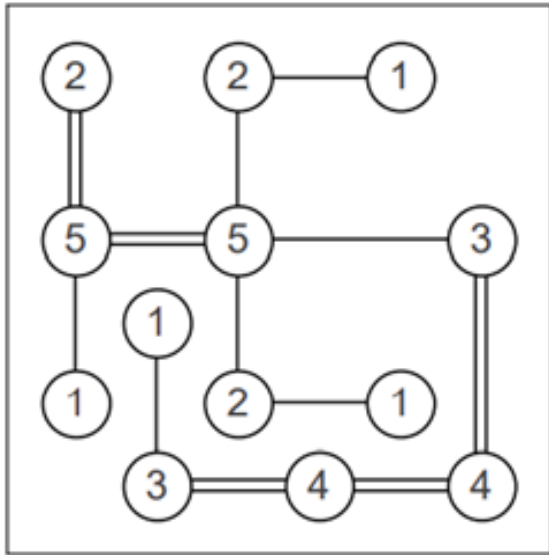

BRAINTEASER

Easter is the only time it is perfectly safe to put all your eggs in one basket!

Winner: Carole S

Runner-up: Allan G

You must watch 'Only Connect'....one of my favourite programmes. Well done to you both.

National u3a Day

We will have a table & display at The Bandstand in Waterlooville on Wed 2nd June 10am–4pm so please tell you friends and neighbours to pop along, have a chat, and find out all about us.

Part of National Volunteer Week, u3as across the UK will be showcasing the learning, activity and fun that happens every day in the u3a.

Members Area of the Website

To visit the members area log on with:

Username: u3amember

Password: u3apassword

Just type in exactly what you see above – all in lower case – no spaces – and not your name! (It's the same username and password for everyone).

Computer Help

Rich Edwards, one of our members, has offered to help members who have problems or queries to do with their computer/PC/ Tablet/iPad. Rich can be contacted on 07786 321 030 OR

richmond.edwards@btinternet.com

South Central Network of u3as

We are one of 19 local u3as that have formed a network to make it easy to swap news and ideas.

This month the Network will be holding a Zoom meeting for all local Group Liaison people that look after the u3a groups.

The SCN website is here:

<https://u3asites.org.uk/hants-sc-network>

Covid vaccines are here

How do they prevent us from getting Covid 19?

Wed 19th May 2021 2pm

This free Zoom talk is being given by Mike Trevethick of Thanet u3a. Mike worked for Pfizer for 15 years as a research group leader initially in gastro-intestinal diseases and subsequently lung biology (asthma and COPD). His talk is very informative, and explains what vaccines are and how they work in a very understandable way.

<https://www.ticketsource.co.uk/whats-on/online/online/covid-vaccines-are-here-how-do-they-prevent-us-from-getting-covid-19/2021-05-19/14:00/t-qoepdj>

National u3a

National u3a are providing free Zoom tutorials on the following topics:

Introduction to Zoom – Multiple dates in May

Zoom for Hosting Group Meetings – Multiple dates in May

Trust Volunteer Induction – 12th May

National u3a are providing free online events delivered via Zoom:

FIRE! – a century of the Volunteer Fire Brigade—Wed, May 12

Behind the Scenes of Dame Mary Quant—Wed, May 12

What Made Us Human? – Thu, 13 May

National Army Museum—Close Shaves & Lucky Escapes—Thu, 13 May

Everything and Anything you would like to know about Yoga in the third age— Fri, May 14

The Kindertransport—Wed, 26 May

The big u3a online debate—Fri, May 28

Staying Safe Online – A u3a Presentation with Q&A—Tue, June 1

Rosa Parks and the Montgomery Bus Boycott—Wed, June 2

u3a Chess – Network Meeting & Online League Discussion—Tue, June 8

The Geology of Britain in the Mesozoic, the Era of Middle Life—Thu, June 3

Beginners Genealogy Course—Tue, 8 Jun

Yoga for Balance—Thu, June 10

National Office produce a monthly Newsletter that all u3a members can subscribe to. Just go to the website, click the Newsletter tab, and subscribe!

The National u3a website is here: www.u3a.org.uk

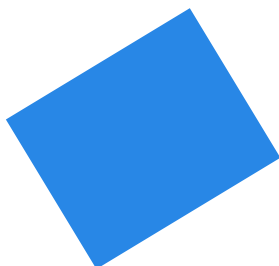

Date of Next Monthly Meeting

Mon 17th May 2pm (via Zoom)

Anyone can do it – A beginner's guide to Science

Speaker: David Gane

davidgane2.wixsite.com/talksandmore

David Gane is an Emsworth u3a member, and a retired teacher and trainer who has taught subjects ranging from Fire Service Control Room IT systems to adult literacy; even at one stage running evening classes in Modern Jive! His talks aim to make scientific subjects clear and entertaining for the general public, and he gave us his talk "When Chimps are smarter than People" last year.

His talk "Anyone can do it – a beginner's guide

to Science", touches on some of the ways our minds are "hard-wired" to give us wrong answers, explains the simple steps scientists follow to try to avoid such errors, and looks at how to tell good science from bad. Along the way he asks: How sure are we that the sun will rise tomorrow? Is Evolution a theory or a fact? Does "standing tall" for two minutes before an interview improve your chances of getting the job?

Unsubscribe?

IF YOU DO NOT WISH TO RECEIVE THIS BULLETIN, please let us know. This bulletin is issued every month to inform our members of Meetings, Groups, Social Events and other information relating to Waterloo u3a, the national u3a and events of interest around the area. Your details can be removed from the bulletin list and a confirmation email sent to you. You can change your mind at any time and request your details to be added back onto the distribution list.

Also, if you wish, you can unsubscribe to the 'Third Age Matters' magazine that is issued five times a year and posted to members.

To unsubscribe to either of these, contact our Membership Secretary on 023 9234 1218 or email members@waterloovilleu3a.org.uk

Useful Contacts

We have various email addresses that you can use and your email will automatically be forwarded to whoever is looking after that role at the time.

almoner@waterloovilleu3a.org.uk	To report a member is ill or has died
beacon@waterloovilleu3a.org.uk	Beacon Administrator
bulletin@waterloovilleu3a.org.uk	Submit an article for this Bulletin
chairman@waterloovilleu3a.org.uk	Chairman
courses@waterloovilleu3a.org.uk	Enquiries for Highbury College courses
equipment@waterloovilleu3a.org.uk	To borrow equipment
events@waterloovilleu3a.org.uk	Meetings Manager
groups@waterloovilleu3a.org.uk	Group Liaison
members@waterloovilleu3a.org.uk	Membership Secretary
secretary@waterloovilleu3a.org.uk	Secretary
speakers@waterloovilleu3a.org.uk	Speakers Secretary
treasurer@waterloovilleu3a.org.uk	Treasurer
groupstreasurer@waterloovilleu3a.org.uk	Groups Treasurer
webmaster@waterloovilleu3a.org.uk	Website matters

Next Bulletin

The deadline for input into the next edition will be Friday 28th May

Email: bulletin@waterloovilleu3a.org.uk

Phone: 023 9217 9298

Post: Kevin Stock, Rose Lodge, 2 London Road, Cowplain, Waterlooville, PO8 8AA

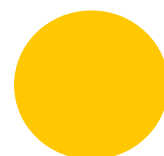

POTENTIAL NEW GROUPS

These groups are waiting for more people to put their names down for them and/or waiting for someone to volunteer to run them. To add your name email groups@waterloovilleu3a.org.uk or phone Kevin Stock on 023 9217 9298

Am Dram

Backgammon

Cribbage 2

Knitting

Members On Their Own

Rock 'n' Roll Trips

ACTIVE GROUPS WITH VACANCIES

Interest Group	Meeting Day	Method
Art	Every Wednesday 2pm – 4pm	Zoom
Art & Design	Ad Hoc	Email
Birdwatching 2	Variable, including Saturdays	Restarted
Board Games (Modern)	Every Thursday 2pm – 4pm	Online
Books 2	Monthly 4 th Friday 2pm – 4pm	Zoom
Books 3	Monthly 4 th Thursday 2pm – 4pm	Zoom
Bridge	Ad Hoc	Online
Canasta 3	Every Monday 2pm – 4pm	Online
Current Affairs 2	Monthly 2nd Thursday 10am – 12 Noon	Restarted
Cycling for Fun	2nd & 4th Mondays 9.30am – 12.30pm	Restarted
Film Study	Ad Hoc	Email
Folk/Roots Appreciation	Monthly 1 st Thursday 2pm – 3.30pm	Zoom
French Conversation 1	Every Tuesday 2pm – 4pm	Zoom
Geology 2	2nd & 4th Monday 2pm – 4pm	Zoom
German Conversation	Monthly 1st Wednesday 1pm – 2.30pm	Zoom
Local History 1	Monthly 3 rd Tuesday 2pm	Zoom
Local History 4	Monthly 3 rd Tuesday 2pm	Restarted
Modern History 1	Fortnightly Monday 10am – 12 Noon	Zoom
National Trust Visits	Ad Hoc	Email
Needle Craft	Ad Hoc	Restarted
Photography 2	Fortnightly Monday 10am – 12 Noon	Restarted
Photography 4	Ad Hoc	Restarted
Play Reading	Ad Hoc	Email
Poetry	Monthly 1st Wednesday 2pm – 4pm	Restarted
Quizzers 1	Monthly 2 nd Thursday 10.30am – 12 Noon	Zoom
Quizzers 2	Monthly 2nd Wednesday 2pm – 4pm	Zoom
Radio Hams	Variable	Radio/Email
Science	Monthly 2 nd Tuesday 2pm – 4pm	Zoom
Spanish Conversation 1	Fortnightly Monday 11am – 1pm	Zoom
Spanish Conversation 2	2 nd & 4 th Wednesday 9.30am – 11.30am	Restarted
Walking 4 – Stragglers	1st Tuesday 2.30pm – 4pm 3rd Tuesday 10.30am – 12 Noon	Restarted

Website: Waterloovilleu3a.org.uk

Follow us on Facebook



u3a day

is on

Wed 2nd June

- **Are you no longer in full time employment?**
- **Do you:**
 - **enjoy the company of others?**
 - **want to learn something new?**
 - **want to maintain skills?**
 - **then come and see us at**

The Bandstand

(Opposite the Halifax)

Waterlooville Precinct

10am - 4pm

- **Discover over 100 group activities and opportunities awaiting you.**
- **We look forward to meeting you.**

